

I BUILTTM PLY

STRUCTURAL PLYWOOD GUIDE

May 2024

- Manufactured to AS/NZS2269:2012 Structural Plywood Standard.
- CD and DD face grades.
- Untreated and treated.
- Square edge and tongue & groove.
- Chain of Custody certified FSC® or PEFC.
- Stress grades F8, F11 and F14.



New Zealand's strongest
pine plywood



Certification for New Zealand

All IBuilt structural plywood is manufactured to AS/NZS 2269.0:2012 Plywood Structural standard. All plywood is 3rd party certified by the following organisations.

Manufacturer	Certifier
PNGFP	EWPA
JNL	EWPA
CMPC	BSI (Benchmark)

Chain of custody

IBuilt's range of structural plywood holds chain of custody certification. This can either be FSC® (Forest Stewardship Council) or PEFC (Programme for the Endorsement of Forest Certification).

Both FSC® and PEFC promote a chain of custody system that tracks the wood from source to the final product, ensuring that the wood fibre contained in the finished product originates from sustainably managed forests.

For a product to qualify for FSC® or PEFC Chain of Custody accreditation, all entities along the supply chain must possess Chain of Custody certification for each program and undergo regular audits.

F8, F11, F14 plywood characteristic properties

Stress Grade	Characteristic Strength, Mpa				Short Duration average Modulus of Elasticity, Mpa (E)	Short Duration average Modulus of Rigidity, Mpa (R)
	Bending (f'b)	Tension (f't)	Panel Shear (f's)	Compression (f'c)		
F8	25	15	4.2	20	9100	455
F11	31	18	4.5	22	10500	525
F14	36	22	4.8	27	12000	625

Characteristic properties for F-Grades as per AS/NZS2269.0:2012, Table 4.1.

Structural plywood identification

Structural plywood is identified by checking the back of the sheet for the following markings:

- Manufacturers name or brand and mill reference
- The word 'Structural'
- Reference to AS/NZS 2269.0:2012
- Stamp identifying 3rd party certifier
- Grade for the face and back veneer (i.e. CD/DD)
- Sheet glue bond. (i.e. A Bond)
- Sheet stress grade. (i.e. F8/F11/F14)
- Panel construction code (i.e. 17-24-7) 17mm thick – 2.4mm face veneer – 7 veneers
- Formaldehyde emission class (i.e. EO)
- If treated, treatment plant and chemical type stamped on the sheet as a separate stamp.

Each plywood sheet is also stamped with the mill code that identifies when the sheet was made, batch and the time of manufacture.

Face grades

Face grades are defined in AS/NZS2269.0:2012 Structural Plywood standard. The standard specifies the amount of splitting and/or knots that are visible on the outer veneers. IBuilt structural plywood is available in the following grades.



C grade - Sound knots less than 50mm and open defects on the face are filled and sanded. Applications could include substrates for membrane systems, formwork, flooring, roofing and bracing.



D grade - Non-appearance grade that contains knots less than 70mm and other unfilled defects. This is the most basic structural panel suited to non-visual structural applications.

Range

IBuilt stock a range of CD and DD grade plywood in 2.4m, 2.7m and 3.0m long lengths. Included in the range is Strong Ply 14™ and Floor Ply 14™ structural plywood which is New Zealand's strongest rated pine plywood and 3.0mm long 12mm F8 - both exclusive to IBuilt.

Treatment

IBuilt structural plywood is treated in accordance with AS/NZS 1604.1:2021 Preservative-treated wood-based products standard. IBuilt's plywood range is available in the following options:

H3.2 CCA

Copper Chrome Arsenic (CCA) treatment leaves a green appearance to the ply sheet. CCA treated plywood is available in all thicknesses.

H3.2 MCA

Micronised Copper Azole treated timber is a non-arsenic based treatment.

H3.1 LOSP

Light Organic Solvent Preservative - Is a green or clear solvent based treatment. Solvent based preservatives can emit a strong odour, ensure the area is well ventilated while the solvent levels reduce during construction.

LOSP based treatment (or H3.1) is available on request only and is subject to terms and conditions.

Note: when using treated plywood it is good practise to re-treat cut ends with a brush on preservative such as Metalex. The treatment process may leave fillet marks on the face of the plywood sheet.

Do not use untreated plywood in weather exposed locations.

Glue bond

Structural plywood utilises a Phenolic Formaldehyde Type A exterior grade adhesive that provides a permanent bond between each veneer once cured. All IBuilt plywood (excluding LOSP treated) achieves an 'EO' emission rating (less than 0.3mg/l).

Weather checking

When smooth faced plywood is used externally, weather cycling causes the face to shrink and swell - over time this causes splits in the face veneer called weather checking. While initially an aesthetic issue, it can eventually cause the face to breakdown and affect durability.

IBuilt recommends CoreClad plywood for cladding applications. CoreClad has a textured face, which when painted protects the sheets from weather checking. Refer to the CoreClad cladding section on the IBuilt website.

Substrate use

Structural ply can be used as a substrate for permanent weather barrier systems such as roofing shingles, tiles, and under membrane systems. A minimum C grade face is recommended for roof and deck membrane systems. Membrane adhesives are not compatible with LOSP based treatments. Refer to the membrane system treatment requirements.

Handling and storage

IBuilt ply should be delivered dry and undamaged from freight and handling. All panels should be inspected upon the delivery. Ply should be lifted off the truck by hoist or hand.

Stack panels horizontally, dry and 100mm clear off the ground and supported on dry, clean timber bearers at maximum of 900mm centres and at both ends of the panels.

Keep ply panels dry at all times, either by storing within an enclosed building or use an additional weatherproof cover as a secondary to packaging wrap if stored outside. Ensure that there is sufficient air flow to avoid condensation. Avoid storing over standing water or vegetation.

Construction exposure

Plywood can withstand normal weather exposure for up to 3 months during construction. If the plywood is intended to be a visual feature, it is recommended that it is protected during construction to minimise any staining or weathering. Where excessive wetting has occurred, all timber should be allowed to return to normal moisture content levels (18%) before being closed in.

Limitations of use

Untreated plywood must not be used externally or in high moisture areas. H3 treated plywood must not be in contact with the ground. It is not recommended to use smooth face plywood as a cladding - refer to IBuilt CoreClad which is manufactured with a textured face veneer specifically for exterior use. Ensure only compatible materials/fixings are in direct contact with the treated plywood.

Plywood general installation

On floor Joists:

When installing plywood on a floor joist system it must be installed perpendicular to the run of joists. Sheets must be fully screwed and glued using a suitable construction adhesive. Construction glue must be used to the full perimeter of the sheet and to all intermediate joists. Fixings generally at 150mm crs to the perimeter of the sheet and at 300mm crs to intermediate supports. Where flooring plywood has been specified as a diaphragm system, install as per the engineer's details.

On wall framing:

Wall framing is to be constructed in accordance with NZS3604:2011 and the New Zealand Building Code. Fixings generally at 150mm crs to the perimeter of the sheet and at 300mm crs to intermediate supports. Where plywood has been specified as a wall bracing system then the fixings shall be installed as per the engineer's details or bracing specification. Refer to the bracing section in this document.

General installation to walls and floors:

Fixings should be 7mm min from sheet edges for square edge panels and 15mm minimum from tongue and grooved edges. Corrosion resistant fasteners (hot dip galvanised steel) must be used when using treated plywood. Stainless steel fixings may be required depending on the application or exposure zone. Stainless steel fixings must be annular grooved.

Recommended plywood fixing

Ply Thickness	Timber Framing		Steel Framing	
	Flat Head	Screws	Thick <1.5mm	Thick <2mm
12	50 x 2.8	8 x 40	10-24-40	10-16-40
15	50 x 2.8	8 x 40	10-24-40	10-16-40
17	60 x 2.8	8 x 50	10-16-45	10-16-45
19	60 x 2.8	8 x 50	10-16-45	10-16-45
21	60 x 2.8	10 x 50	10-16-45	10-16-45
25	75 x 3.15	10 x 50	10-16-45	10-16-45

Expansion gaps and blocking

2-3mm expansion gaps must be left to the square ends of the sheets to allow for expansion when installed as flooring and roofing. The tongued edge can be installed with no gap as there is a relief rebate on the back face of the sheet which allows for expansion and contraction. Tongue and groove joints do not require additional support under the sheet edges unless specified by the engineer or designer. All square edges of the ply sheet must be fully supported by framing or solid blocking.

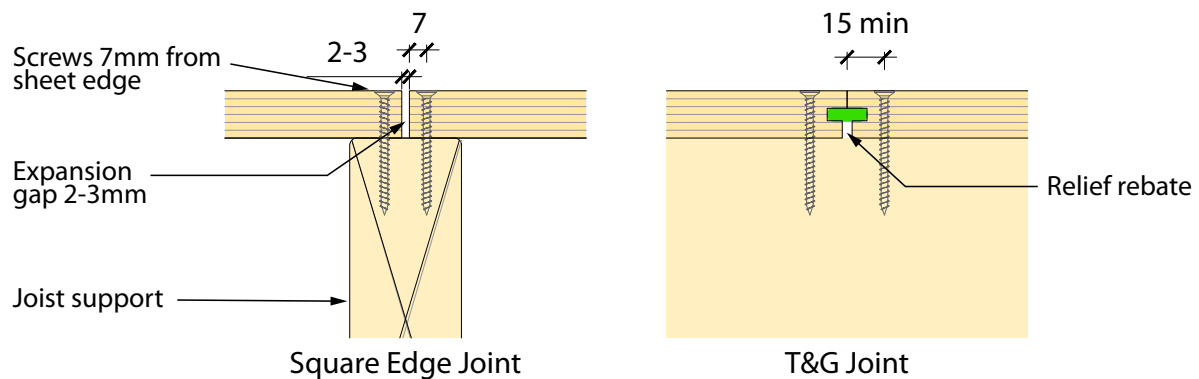

Bracing types

Brace Code	Selex ply brace type	Min Brace Length	BU's per m (Wind)	BU's per m (EQ)
BP1 0.4m	7mm Ply 1 Side + Hold down brackets	0.4m	84	99
BP1 0.6m	7mm Ply 1 Side + Hold down brackets	0.6m	104	114
BP1 1.2m	7mm Ply 1 Side + Hold down brackets	1.2m	134*	141*
BPG 0.4m	7mm Ply 1 Side with 10mm Gib® Standard lining other side + Hold down brackets	0.4m	89	100
BPG 0.6m	7mm Ply 1 Side with 10mm Gib® Standard lining other side + Hold down brackets	0.6m	117	136
BPG 1.2m	7mm Ply 1 Side with 10mm Gib® Standard lining other side + Hold down brackets	1.2m	182*	177*

*Note: Bracing Panels must not exceed 120 BU/m when used on a timber framed floor or 150 BU/m when on a concrete floor slab without specific design as per NZS3604:2011 Section 5.4.2. These bracing values can also be applied to any F8 Structural Selex Ply panel with a minimum thickness of 7mm.

Installation of IBuilt Selex ply bracing

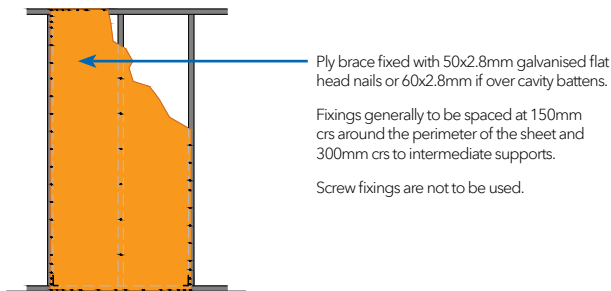

BP1 - Selex F8 Ply 1 side

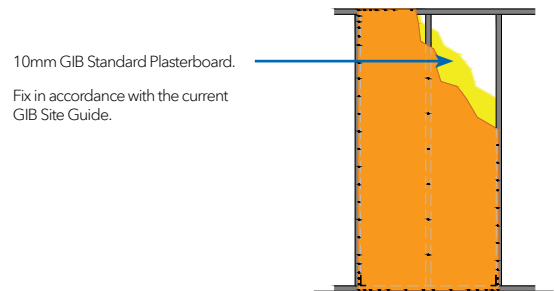

BPG - Selex F8 Ply 1 side + GIB Standard

Fixing requirements to corners

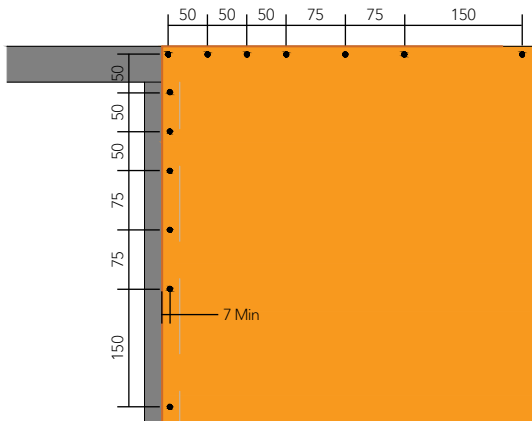

GIB® Plasterboard for BPG brace

GIB® plasterboard when installed as bracing must be installed in accordance with GIB® Bracing System specifications as detailed in the current GIB® Site Guide. Failure to follow GIB® Bracing System specifications could result in the bracing panel not achieving the required bracing resistance.

GIB® sheets may be installed vertically or horizontally, with sheet edges touching, joints stopped and reinforced in accordance with the GIB® Site Guide.

Fixings are to be in accordance with all current installation literature.

GIB HandiBrac® installation

Timber floor - External wall

12kN characteristic uplift strength on timber floors

GIB HandiBrac® bracket

Locate the GIB HandiBrac® bracket such that the coach screw/ BOWMAC screw bolt is centred over the joist or bearer below

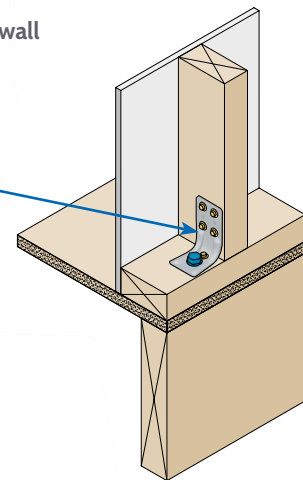

Concrete floor - External wall

15kN characteristic uplift strength on concrete slabs

GIB HandiBrac® bracket

To maximise concrete edge distance, locate the GIB HandiBrac® bracket flush with the inside face of the stud

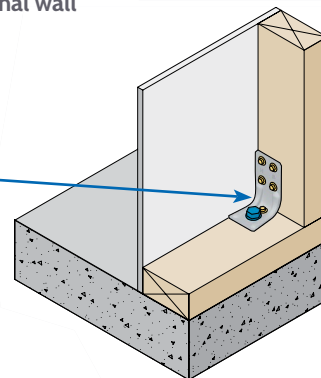

Also refer to GIB HandiBrac installation documents for further information

Bracing panel fixing notes

- Ply bracing elements must be fixed onto wall framing designed in accordance with NZS3604:2011 and complies with the New Zealand Building Code clauses B1 Structure and B2 Durability.
- Ply bracing elements must be treated to H3.2 hazard class when used in high moisture areas or used on external wall framing. Untreated ply bracing can be used in interior bracing applications.
- Ply sheets should be fixed using 50mm x 2.8mm flat head nails for direct fixing to framing, or 60mm x 2.8mm flat head nails when fixing over cavity battens. Fixings can be hand or power driven. Fixings to corners to be at 50,50,50,75,75mm crs then 150mm crs around the perimeter of the sheet and 300mm crs through the centre. Screw fixings are not to be used.
- At a minimum, hot dipped galvanised nails are to be used when in contact with treated timber. In some instances stainless steel fixings may be required depending on the application or exposure zone. When stainless steel fixings are used they must be annular grooved.
- Allow a 3mm gap between ply sheet edges to allow for any expansion in the ply sheet.
- When multiple ply sheets, or part sheets have made up a bracing element, each sheet must be nailed off independently and be fully supported and fixed to studs or noggs.
- For bracing elements greater than 2.4m in height refer to NZS3604:2011 clause 8.3.1.4 'Adjustment of bracing elements for height'.

Structural flooring and roofing span tables

Strong Ply 14™ and Floor Ply 14™ are New Zealand's strongest pine plywood. They are both available in 15mm-25mm, CD and DD grades. Strong Ply 14™ is square edged (SE) and Floor Ply 14™ is tongue and groove (T&G).



Strong Ply 14™ and Floor Ply 14™ flooring span table

Application	UDL (Kpa)	CONC (kN)	Sheet Length (m)	Span (mm)				
				15mm	17mm	19mm	21mm	25mm
Domestic flooring and decking	2.0	1.8	2.4m	400	480	600	800	800
Office	3.0	2.7	2.4m	343	400	480	600	800
Retail	4.0	3.6	2.4m		343	400	480	800
Industrial	5.0	4.5	2.4m			343	480	600
Domestic Garage	2.5	9.0	2.4m			300	343	480

Strong Ply 14™ and Floor Ply 14™ roofing span table

Application	UDL (Kpa)	CONC (kN)	Sheet Length (m)	Span (mm)				
				15mm	17mm	19mm	21mm	25mm
Light roof 0-10°	0.25	1.1	2.4m	900	900	900	1200	1200
Light/Heavy roof 10-20°	0.25	1.1	2.4m					
Light/Heavy roof 20-30°	0.25	1.1	2.4m					
Light/Heavy roof 30-45°	0.25	1.1	2.4m					
Light roof up to 10°	0.25	1.8	2.4m	800				

2.7m 19mm F8 plywood span table

Application	UDL (Kpa)	CONC (kN)	Sheet Length (m)	Span (mm)
Domestic flooring and decking	2.0	1.8	2.7m	540
Office	3.0	2.7	2.7m	450
Retail	4.0	3.6	2.7m	300
Industrial	5.0	4.5	2.7m	225
Domestic Garage	2.5	9.0	2.7m	270

NZWOOD

NEW ZEALAND WOOD PRODUCTS LIMITED



149 Kerrs Rd, Wiri, Auckland



PO Box 76412, Manukau, Auckland 2241, New Zealand



Tech Info Line: 0800-022-352



Phone: +64-9-268 6540



sales@ibuilt.co.nz
techinfo@ibuilt.co.nz



www.ibuilt.co.nz